

MOOHA

WATER HAMMER SHOCK ABSORBER



M O O H A

MOOHA

WATER HAMMER SHOCK ABSORBER



Introduction

Water hammer is a complicated process that exists in many water piping systems. Water shock waves are caused by the rapid closing and opening of valves or the improper design of a water piping system. The result is water hammer, which may reduce the service life of piping system components and accessories.

After extensive design and testing, Tozen has developed a unique solution to the potential damage caused by uncorrected water hammer. The MOOHA calms and smooths the water shock wave, so that system integrity is maintained. The MOOHA has been field proven in various applications to solve water hammer problems.

Features

1. Fast Response

The MOOHA responds quick and effectively to eliminate water hammer problems that reduce system life and effect normal water flow.

2. Simple Installation

MOOHA's compact design requires minimal space and can be connected directly in series with the piping in almost any direction.

3. High Durability and Economy

MOOHA is designed for maximum life at an affordable, competitive price. The outer casing is constructed of mild steel and the elastic interior of the specially selected synthetic rubber.

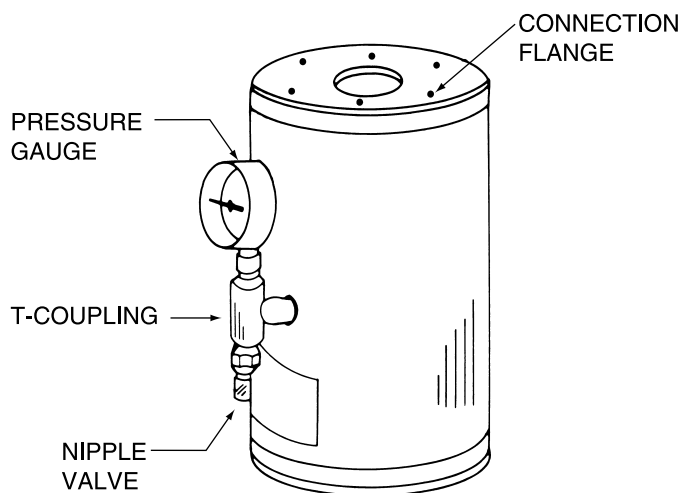

PT-MOOHA® is patented
in USA, CANADA and AUSTRALIA
PATENT NO. 4186775 (USA)
1047365 (CANADA)
485621 (AUSTRALIA)

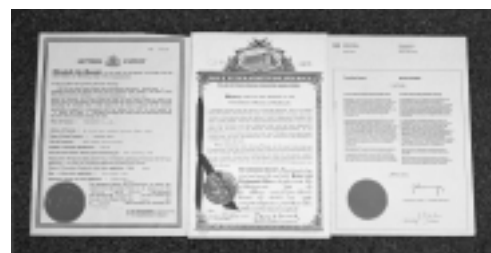

Installation Location

Install MOOHA at locations of water hammer source as close as possible as follows.

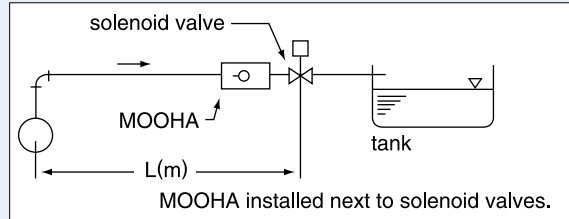
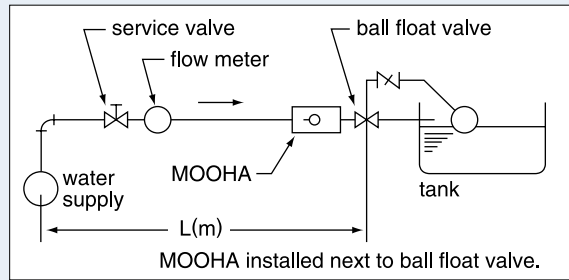
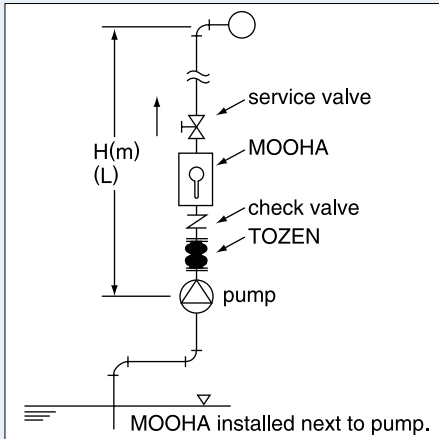

Off-line installation is also available as follows.

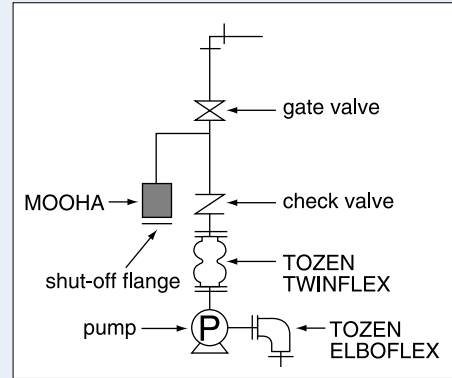
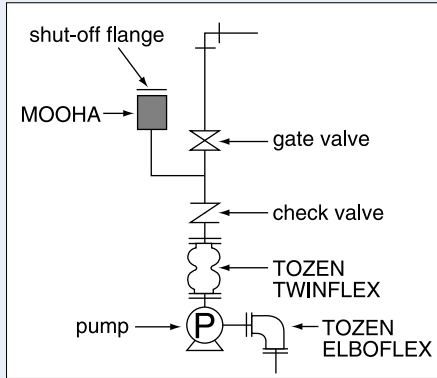

Example of Installation



Installation in riser for lift pump



Pressure Durability Test



Off-line installation



Installation in riser

Notes

1. The air chamber pressure is pre-set at the factory at 0.5Mpa. Optimum chamber pressure will be approximately 50% of the maximum working pressure and can be adjusted by increasing or decreasing pressure through the nipple valve.
2. Prior to installation, check to ensure hex. socket head cap screws are in place and fastened.
3. When placing order, please advise of the pipe diameter, pipe layout, flow velocity, working pressure, water hammer source, etc.

Construction

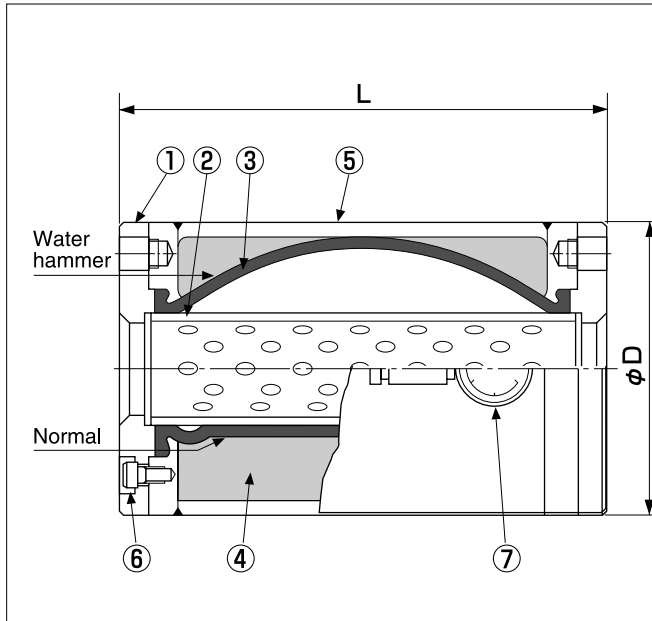

No.	Parts	Materials
①	Flange	Mild Steel (SS400)
②	Perforated Pipe	PVC Pipe (HTPVC)
③	Elastic Tube	Synthetic Rubber
④	Air Chamber	Enclosure of Nitrogen Gas
⑤	Casing	Mild Steel (SS400)
⑥	Hex.Socket Head Cap Screw	Carbon Steel
⑦	Pressure Gauge	c/w Nipple Valve

- Flange drilling to JIS, BS, DIN, etc. are available as specified.
- Flange material is changeable to SUS304 and SUS316.
- Casing material is changeable to SUS304 and SUS316.

Dimensions

Model	Nominal Dia. (A)	Dimensions (mm)		Air Chamber Capacity (ℓ)	Mass (kg.)
		φD	L		
MH-25	25	127	156	1	6
MH-50	50	165	266	3	13
MH-80	80	191	376	6	19
MH-100	100	216	440	8	27
MH-125	125	267	556	16	44
MH-150	150	319	640	27	66

- Mass indicates only the case with JIS 10K flanges.

Operating Conditions

Max. Working Pressure

: 1.6Mpa {16.3kgf/cm²}

Max. Working Temperature : 60°C

Applicable Fluids : Water, Seawater, Cooling and Heating water, etc.

- Please check max. working pressure and max. working temperature to be within the operating conditions.

Operation of MOOHA

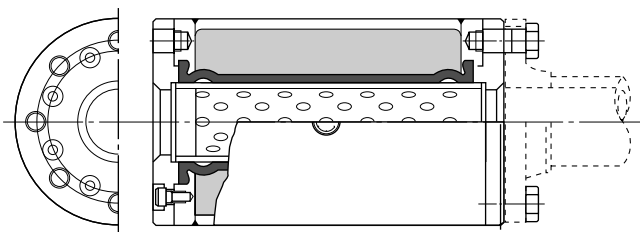

Under normal flow conditions, water flows through the perforated pipe of the MOOHA without any change in the flow characteristics. When the water pressure exceeds a set level, the elastic tube expands and when the water pressure is lower than the set point, the elastic tube maintains its standard configuration. As water pressure changes, as with a surge in water flow, the elastic tube expands and contracts, thus regulating and calming the water in the pipe.

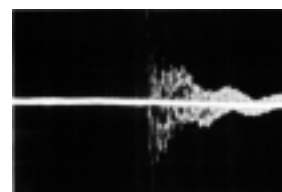

Unregulated-without MOOHA

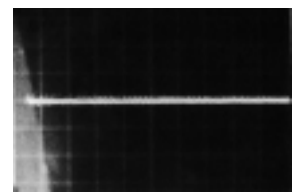

Unregulated-with MOOHA



■ Selection of MOOHA

1. Surge Pressure of Water Hammer : Ps

$$P_s \cong \text{Flow Velocity (m/s)} \times 1.37 \{14\} = \boxed{} \times 1.37 \{14\}$$

$$= \underline{\hspace{2cm}} \text{ MPa \{kgf/cm}^2\}$$

2. Relationship with Max. Impact Pressure Pb and Normal Working Pressure P

$$\frac{P_b}{P} = \frac{P_s + P}{P} = \frac{\boxed{} + \boxed{}}{\boxed{}} = \underline{\hspace{2cm}} \text{ times}$$

3. Calculation for Absorption Capacity

$$q = 4 \times 10^{-3} \times \frac{\lambda}{\lambda - 1} (0.0164 L - t) \eta$$

Note : q = Required capacity of pressure absorption _____

Q = Flow rate _____ /min.

λ = Ratio of allowable water hammer pressure (Pm) and normal working pressure (P)

$$\lambda = \frac{P_m}{P} = 1.5 \text{ (where not specified specially)}$$

L = Total piperun _____ m

t = Closing time of valve or pump (normally 0.2 sec.)

η = Coefficient factor 0.5

$$q = 4 \times 10^{-3} \times \frac{1.5}{1.5 - 1} \times \boxed{\text{Flow rate}} (0.0164 \times \boxed{\text{Piperun}} - 0.2) \times 0.5$$

$$= 0.006 \times \boxed{\text{Flow rate}} (0.0164 \times \boxed{\text{Piperun}} - 0.2)$$

$$= \underline{\hspace{2cm}}$$

4. Selection of Model and Size

Compare the value of “q”, obtained in item #3 above to air chamber capacity by model contained in the Table of Dimensions to obtain the appropriate model Mooha. Consequently,

$$\text{MOOHA MH} - \boxed{} = (\text{Air Chamber Capacity} \underline{\hspace{2cm}}) \times \underline{\hspace{2cm}} \text{ pcs.}$$

to be installed as close as possible to water hammer source.



Operating conditions and other performance data published in this catalog have been developed from our design calculation, in-house testing, field reports provided by our customers and/or published official standards or specifications. They are good only to cover typical applications as a general guideline to users of TOZEN products introduced in this catalog.

For any specific application, users are kindly requested to contact TOZEN SANGYO CO., LTD. for technical advice, or to carry out their own study and evaluation for providing suitability of these products to such an application. Failure to follow this request could result in property damage and/or personal injury, for which we shall not be liable.

While this catalog has been compiled with the utmost care, we assume no responsibility for errors, impropriety or inadequacy. Any information provided in this catalog is subject to from-time-to-time change without notice for error rectification or, product discontinuation, design modification, new product introduction or any other cause that TOZEN SANGYO CO., LTD. considers necessary. This edition cancels all previous issues.

※ The contents of this literature are subject to change without notice.

AGENT

TOZEN SANGYO CO., LTD.

8-4, Asahi, Yoshikawa
Saitama 342-0008
Japan

Phone : (048)993-1035
Fax : (048)993-1018